

## X30 SUPER 175cc RL TaG



### FEATURES - CARACTERISTIQUES

Cylinder volume <i>Volume du cylindre</i>	174.56 cm <sup>3</sup> (175.5 cm <sup>3</sup> max.)
Bore <i>Alésage</i>	63.92 mm
Max. theoretical bore <i>Alésage théorique max.</i>	64.06 mm
Stroke <i>Course</i>	54.40 mm
Cooling system <i>Système de refroidissement</i>	Water
Inlet system <i>Système d'admission</i>	Reed valve

Carburettor <i>Carburateur</i>	Tillotson HB-10A (Ø34mm)	Cylinder/crankcase transfers n° <i>N° de canaux cylindre / carter</i>	5 / 3
Number of piston rings <i>Nombre de segments</i>	1	Inlet / exhaust ports number <i>N° lumières admiss. / échapp.</i>	5 / 3
Crankshaft bearing diam. <i>Diamètre palier du vilebrequin</i>	30x62x16 (2Pc.)	Combustion chamber shape <i>Forme chambre de combustion</i>	Spherical <i>Spherique</i>
Big end conrod bearing diam. <i>Diamètre palier tête de bielle</i>	20x26x15	Selettra ignition <i>Allumage Selettra</i>	Digital S
Small end conrod bearing diam. <i>Diamètre palier pied de bielle</i>	15x19x20	RPM limiter <i>Limiteur de vitesse</i>	Yes <i>Oui</i>
Distance between conrod centers <i>Longueur (entre axe) de la bielle</i>	104 mm	Centrifugal Dry Clutch <i>Embrayage Centrifuge à sec</i>	Yes <i>Oui</i>
Balancing shaft <i>Arbre d'équilibrage de vilebr.</i>	Yes	Electric starter <i>Démarrateur électrique</i>	Yes <i>Oui</i>

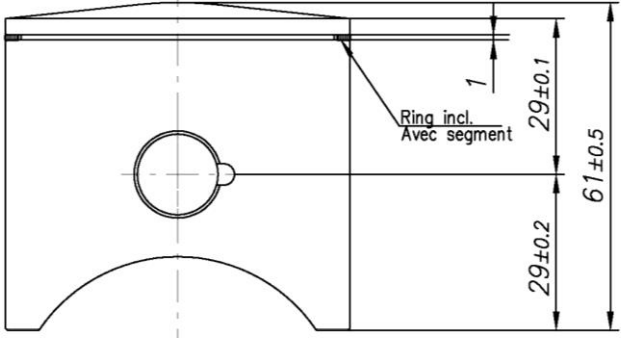
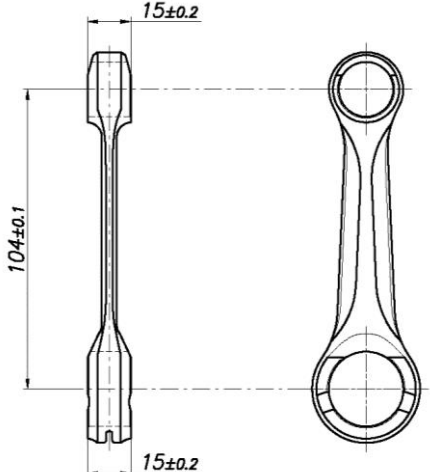
DESCRIPTION OF THE MATERIAL DESCRIPTION DES MATERIAUX		PISTON
Conrod material <i>Matériel de la bielle</i>	Steel <i>Acier</i>	 <p>Piston min. weight (ring incl.) 162 g Poids Min. (avec segment) 162 g</p>
Crankshaft material <i>Matériel du vilebrequin</i>	Steel <i>Acier</i>	
Balancing shaft material <i>Matériel de l'arbre d'équilibrage</i>	Steel <i>Acier</i>	
Gears material <i>Matériel des engrenages</i>	Steel <i>Acier</i>	
Starter ring material <i>Matériel de la couronne démarr.</i>	Steel <i>Acier</i>	
Cylinder head material <i>Matériel de la culasse</i>	Aluminium	
Cylinder material <i>Matériel du cylindre</i>	Aluminium	 <p>Min. weight 117 g Poids Min. 117 g</p>
Liner material <i>Matériel de la chemise</i>	Cast iron <i>Fonte</i>	
Crankcase material <i>Matériel du carter</i>	Aluminium	
Piston material <i>Matériel du piston</i>	Aluminium	
Piston ring material <i>Matériel du segment</i>	Steel <i>Acier</i>	
Exhaust muffler material <i>Matériel du pot d'échappement</i>	Sheet-steel <i>Tôle acier</i>	

**CRANKSHAFT  
VILEBREQUIN**

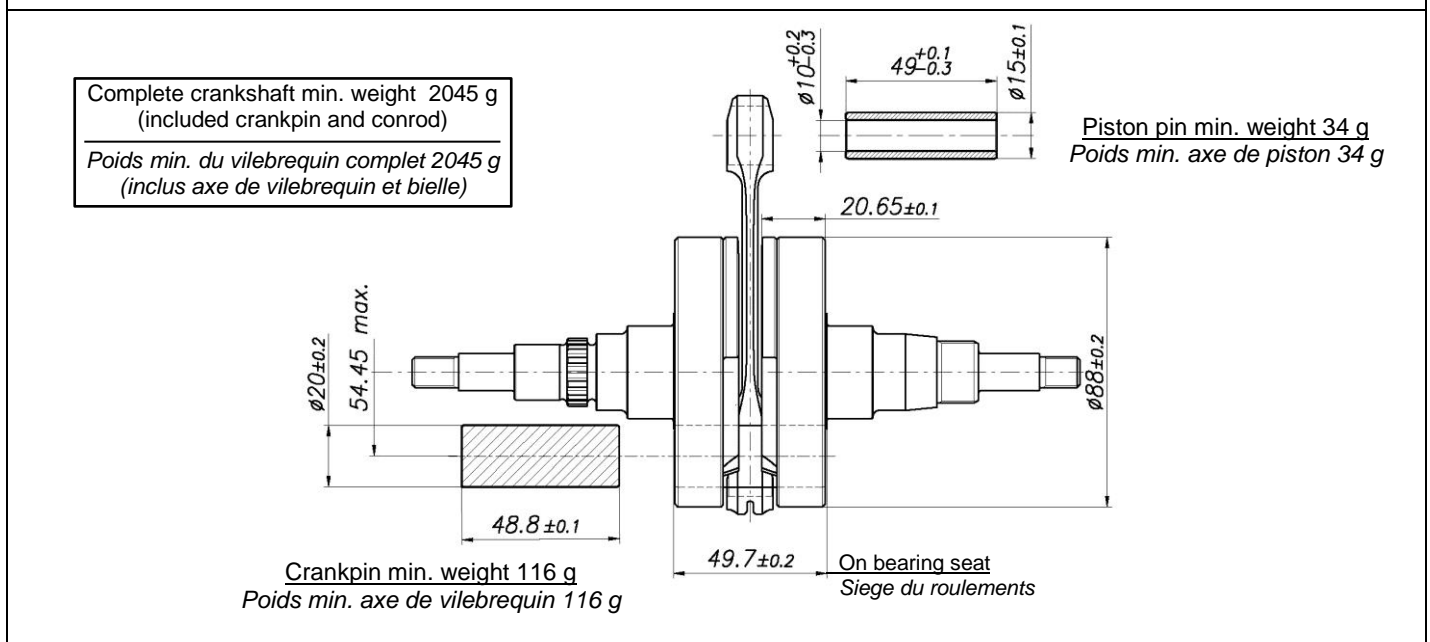

BALANCING SHAFT - ARBRE D' EQUILIBRAGE

**TYPE 1**

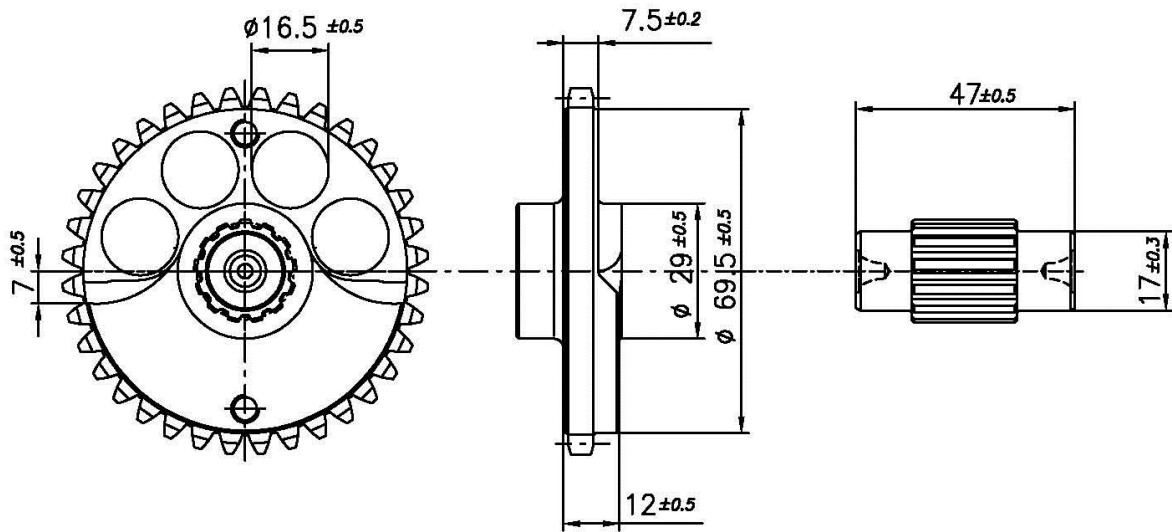

Tot. Min. weight 332 g  
*Poids min. tot. 332 g*

**TYPE 2**

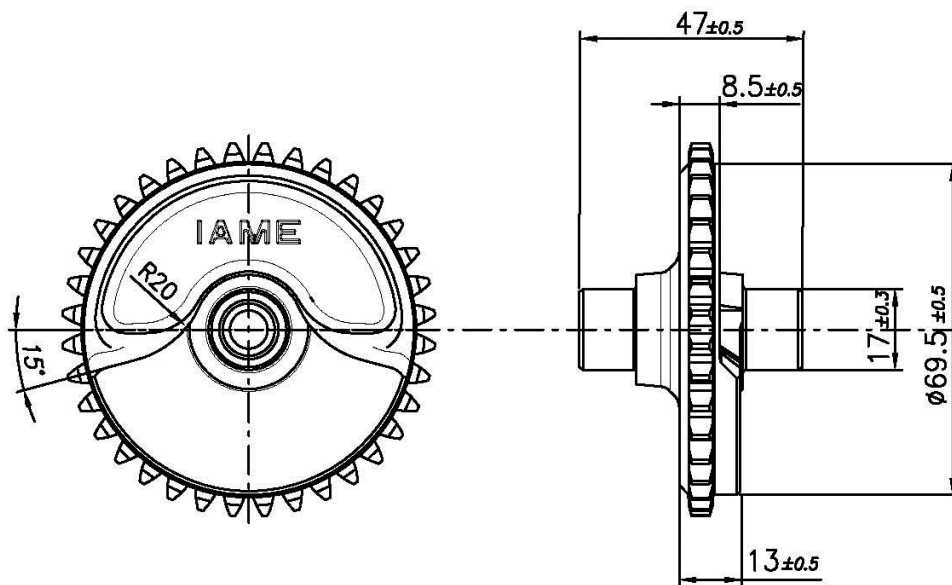

Tot. Min. weight 320 g  
*Poids min. tot. 320 g*

CYLINDER DEVELOPMENT - DEVELOPPEMENT DU CYLINDRE

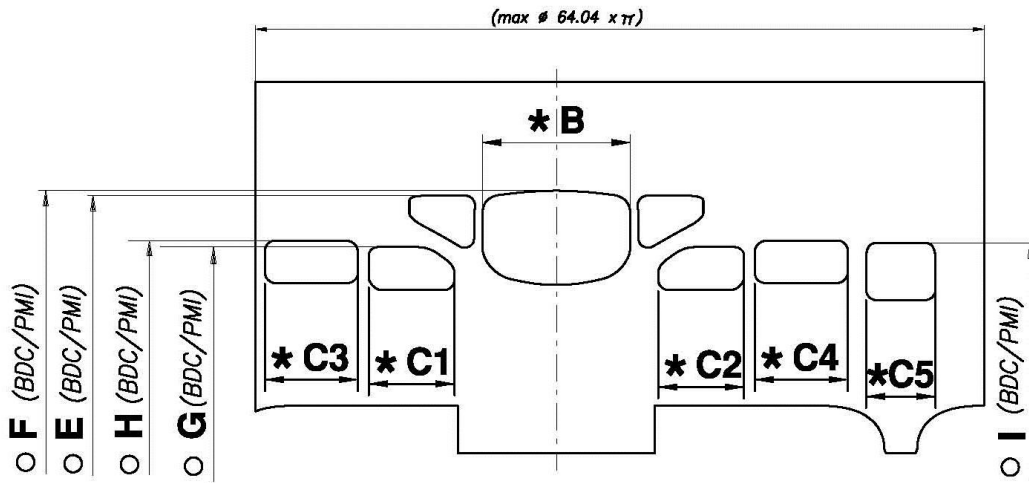

<b>B</b>	≤ 40.5 mm
<b>C1 = C2</b>	≤ 25 mm
<b>C3 = C4</b>	≤ 27 mm
<b>C5</b>	≤ 20.5 mm
<b>E</b>	182.0° ±2°
<b>F</b>	186.0° ±2°
<b>G</b>	125° ±2°
<b>H</b>	128° ±2°
<b>I</b>	124.5° ±2°

\*CHORDAL READING  
LECTURE CORDALE

○ ANGULAR READING BY INSERTING A 0.2x5 mm GAUGE  
LECTURE ANGULAIRE PAR INSERTION D'UNE CALE DE 0.2x5 mm

CYLINDER BASE VIEW  
VUE DE LA BASE DU CYLINDRE

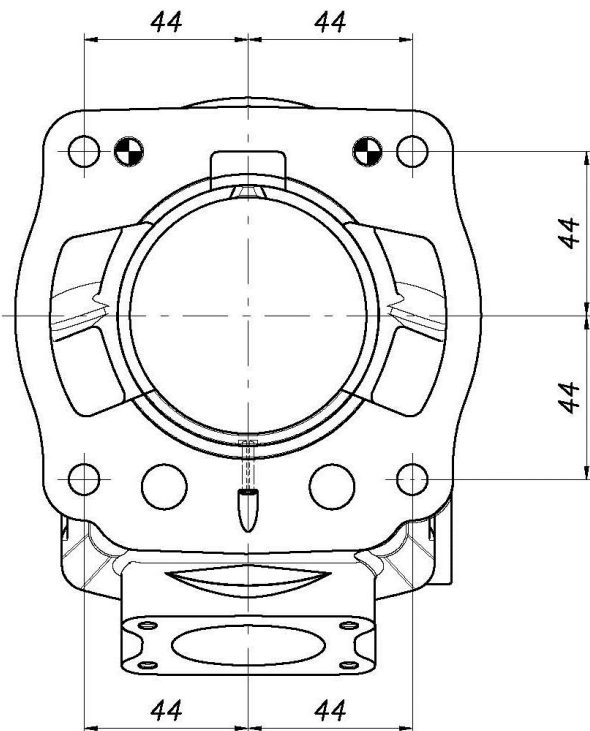

CYLINDER CROSS SECTION VIEW  
VUE EN SECTION DU CYLINDRE

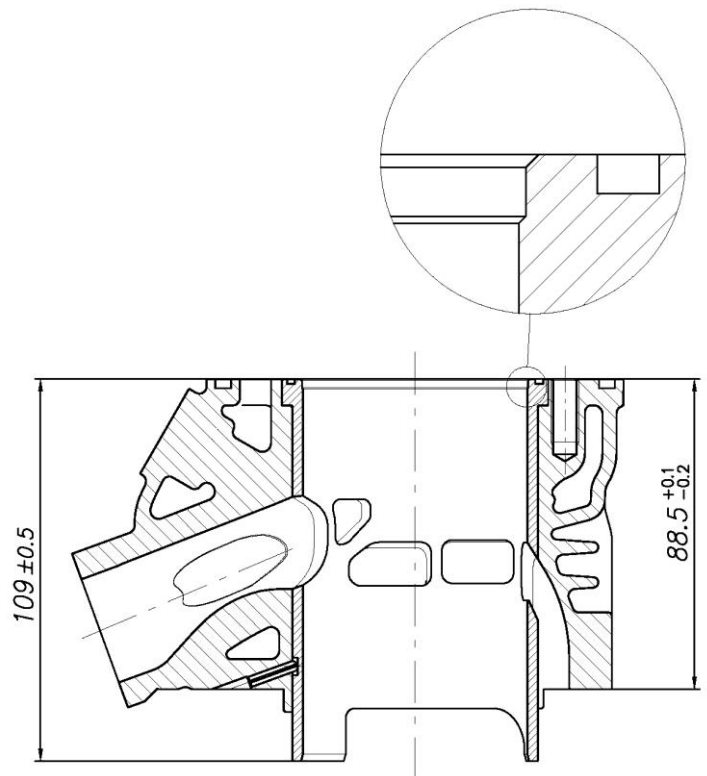

COMBUSTION CHAMBER VIEW  
VUE DE LA CHAMBRE DE COMBUSTION

( Volume 2 cm<sup>3</sup> )  
( Plot a' Insert 2 cm<sup>3</sup> )

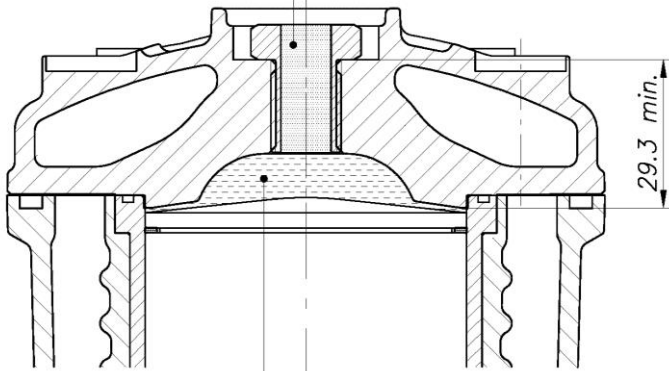

Volume min. 11,8 cm<sup>3</sup>

COMBUSTION CHAMBER VOLUME TOT. = 13.8 cm<sup>3</sup> min.  
VOLUME CHAMBRE COMBUSTION TOT. = 13.8 cm<sup>3</sup> min.

ATT.: SQUISH MIN. = 0.85 mm  
(measured with Ø1.5mm TIN - mesurée avec de l'étain Ø1.5mm)

CRANKCASE INSIDE VIEW  
VUE A' L' INTERIEUR DU CARTER

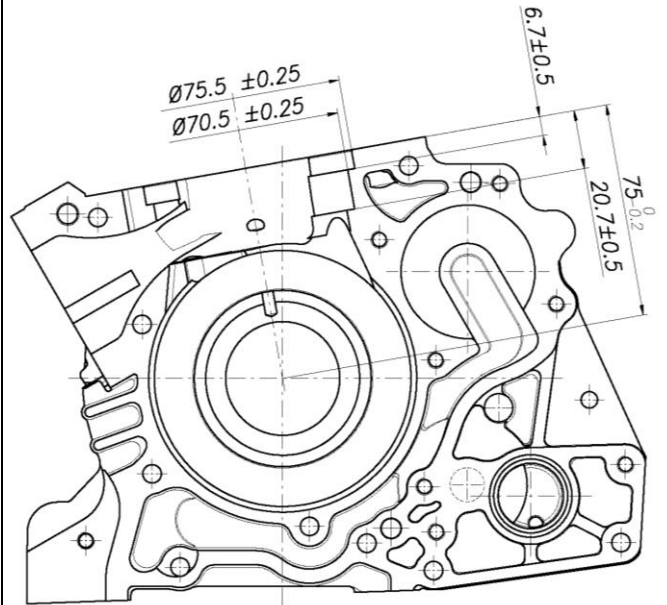

REEDS GROUP & REEDS DIMENSIONS – PYRAMIDE DE CLAPETS & CLAPETS

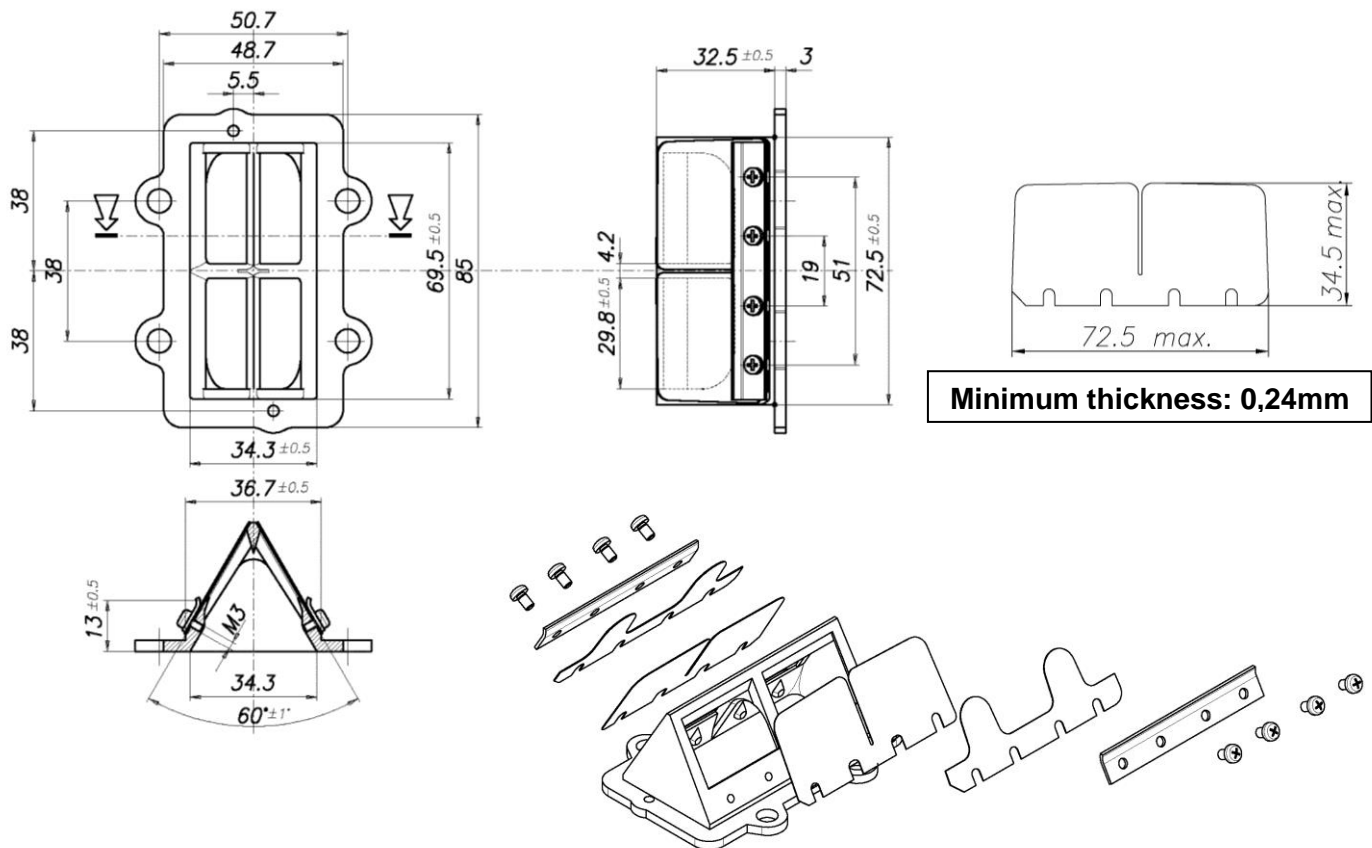

INLET CONVEYOR - CONVOYEUR D'ADMISSION

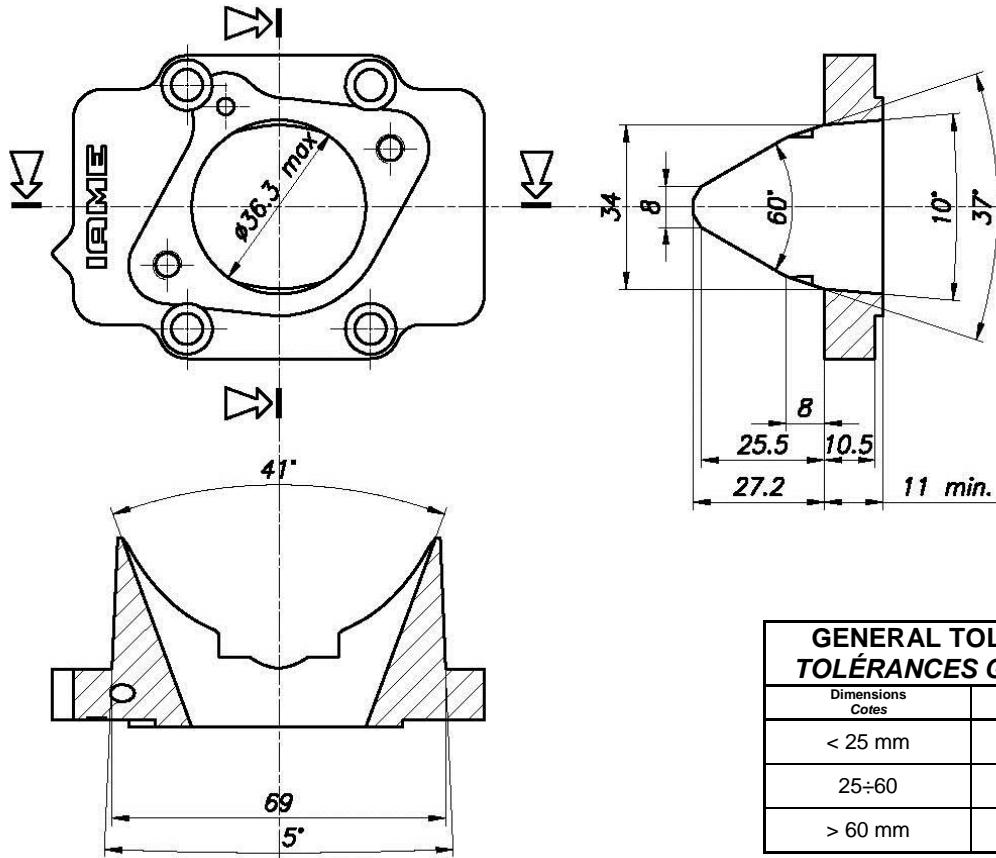

GENERAL TOLERANCES TOLÉRANCES GÉNÉRALES	
Dimensions Cotes	Machined parts Pièces usinées
< 25 mm	±0.5
25÷60	±0.8
> 60 mm	±1.5

INLET SPACER - RACCORD D'ADMISSION

PART N° cod. TFB-41900

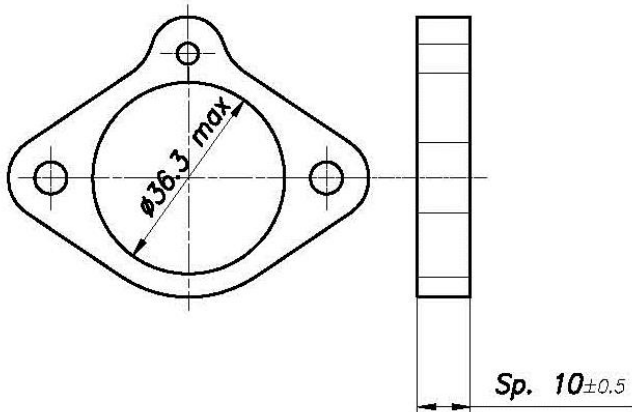

VENTURI CARB. DIMENSIONS  
DIMENSIONS DU VENTURI DU CARB.

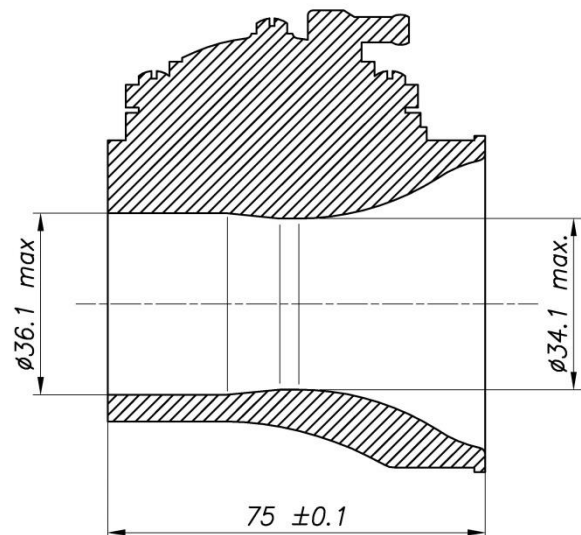

DESCRIPTION OF THE CLUTCH - DESCRIPTION DE L' EMBRAYAGE

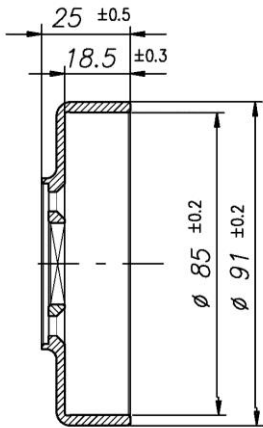
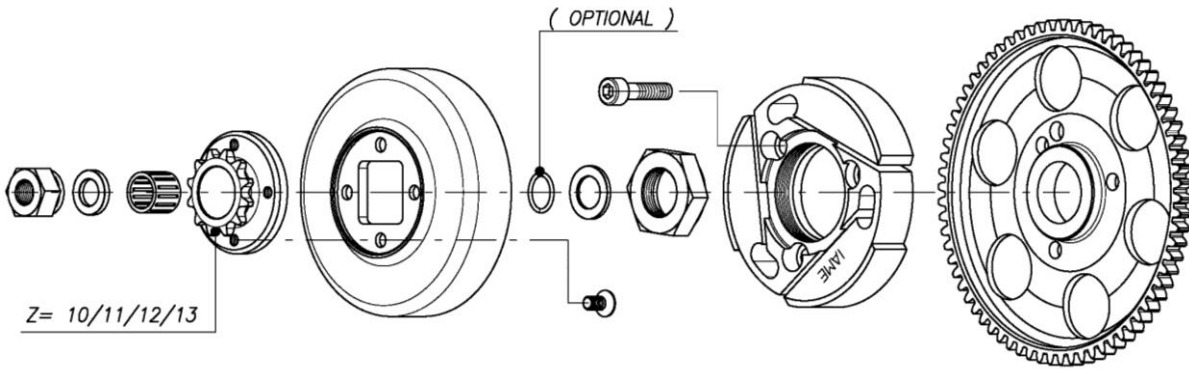

Min. weight 225 g  
Poids min. 225g

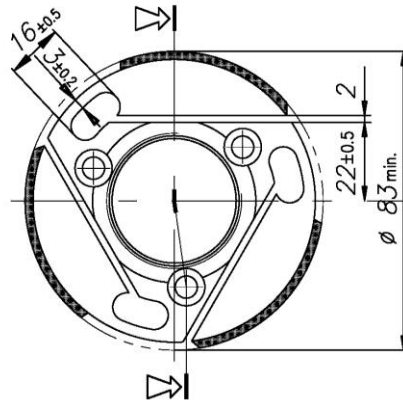

Min. weight 375 g  
Poids min. 375g

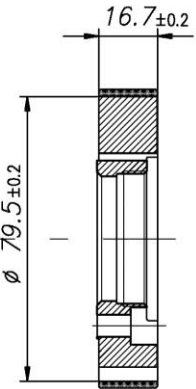

WEIGHT MIN. OF THE CLUTCH – POIDS MIN. DU EMBRAYAGE

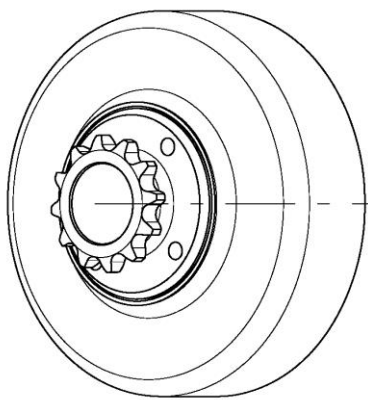

Min. weight 300 g  
Poids min. 300 g

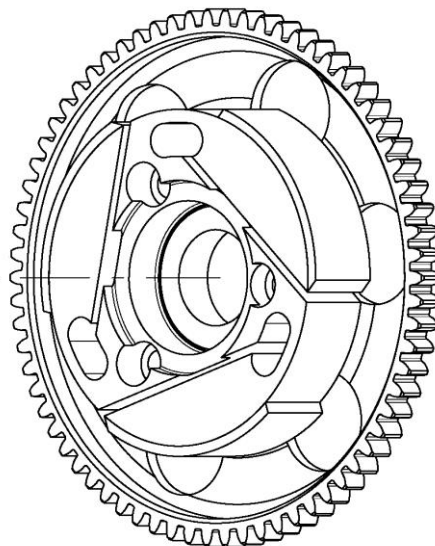

Min. weight 680 g  
Poids min. 680 g

WIRING DIAGRAM (SELETTRA DIGITAL "S" IGNITION )  
 SCHEMA CIRCUIT ELECTRIQUE (ALLUMAGE SELETTRA DIGITAL "S")

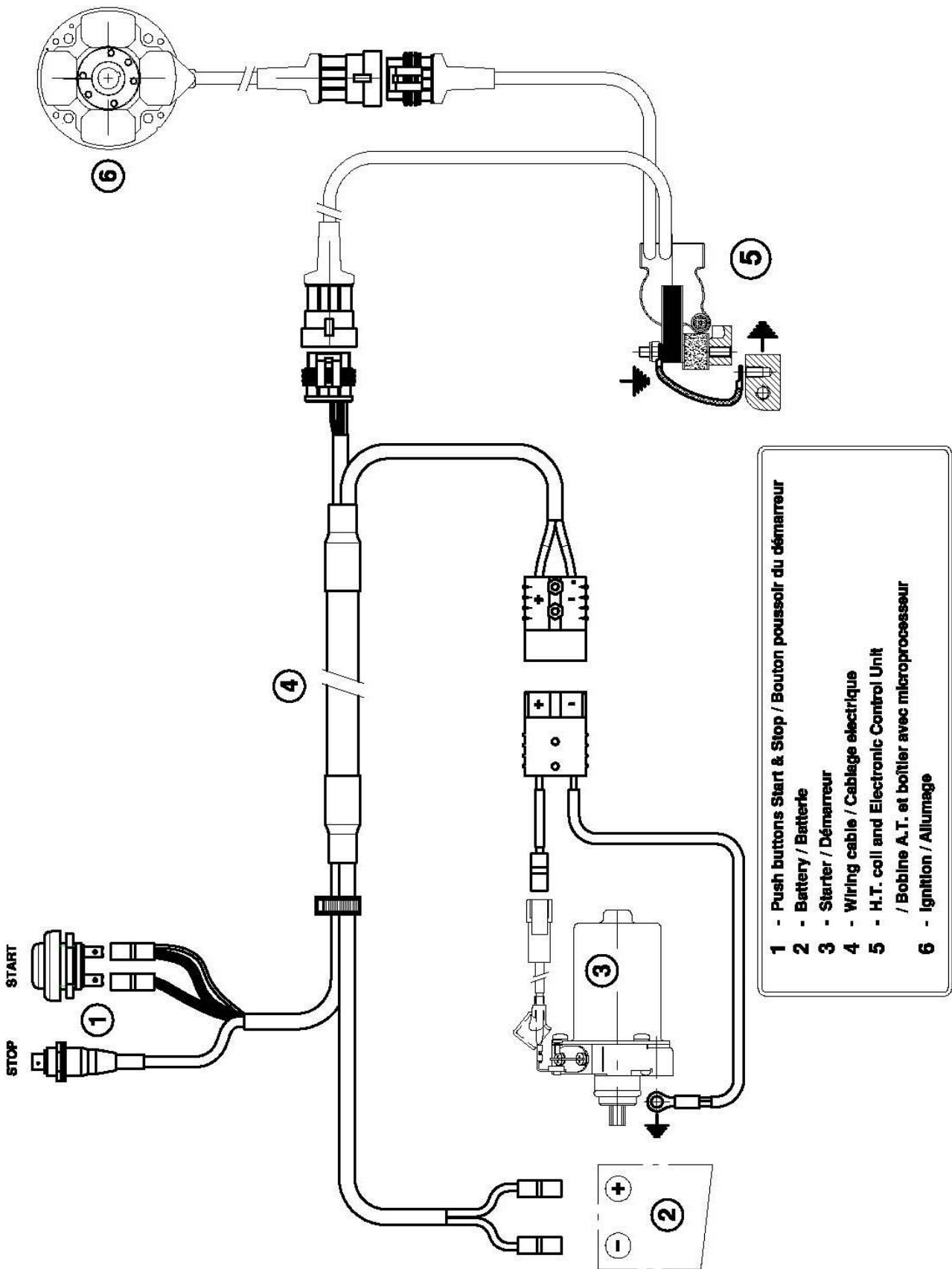

- 1** - Push buttons Start & Stop / Bouton poussoir du démarreur
- 2** - Battery / Batterie
- 3** - Starter / Démarreur
- 4** - Wiring cable / Cablage électrique
- 5** - H.T. coil and Electronic Control Unit / Bobine A.T. et boîtier avec microprocesseur
- 6** - Ignition / Allumage



SCHEME FOR ADVANCE CONTROL  
SCHEMA DE CONTROLE POUR L'AVANCE

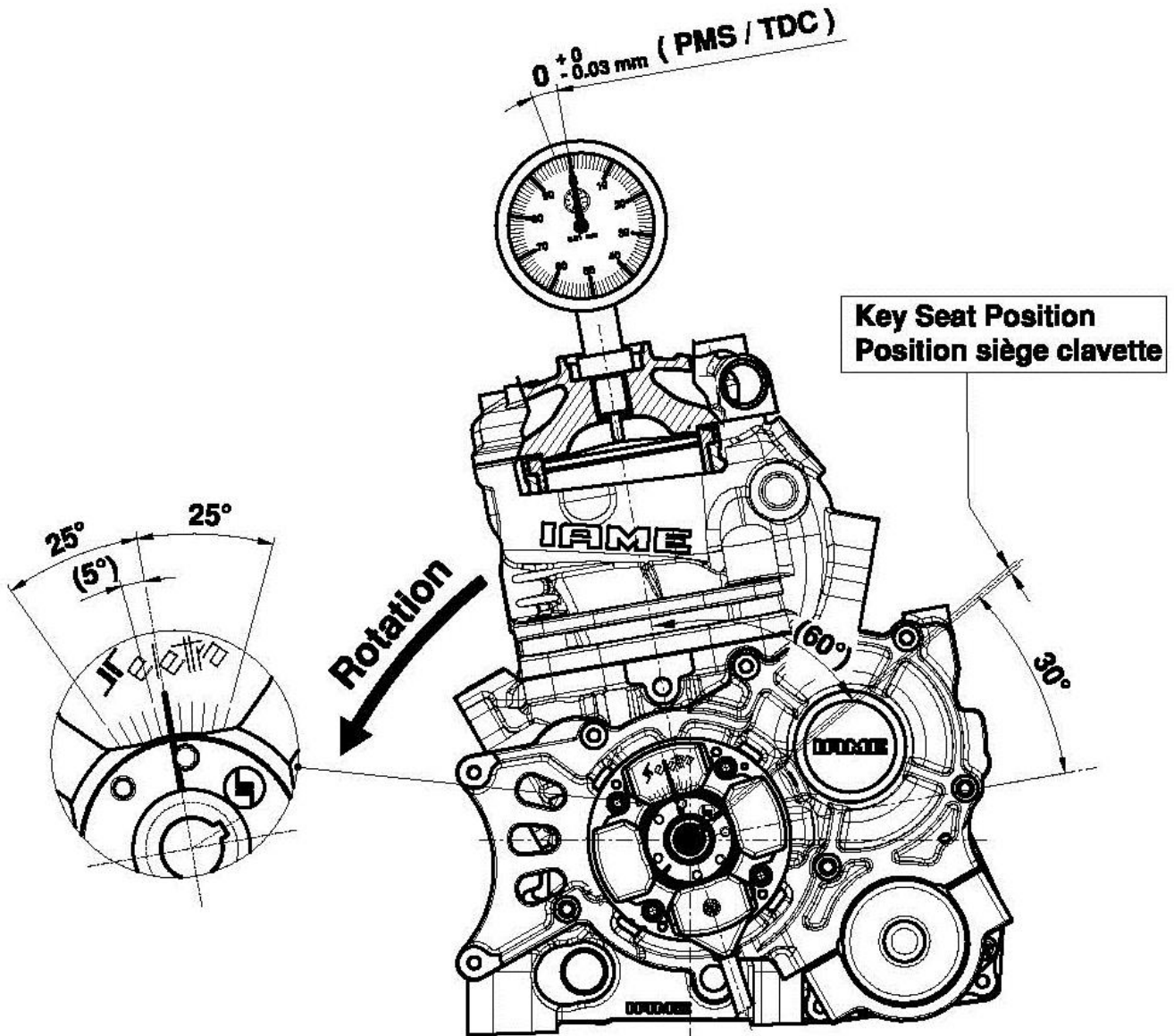

COMPLETE WIRING LOOM – PHOTO DU CABLAGE ELECTRIQUE



PHOTO OF SELETTRA DIGITAL "S" IGNITION WITH "IAME" MARKING  
PHOTO DU ALLUMAGE SELETTRA DIGITALE "S" AVEC MARQUAGE "IAME"

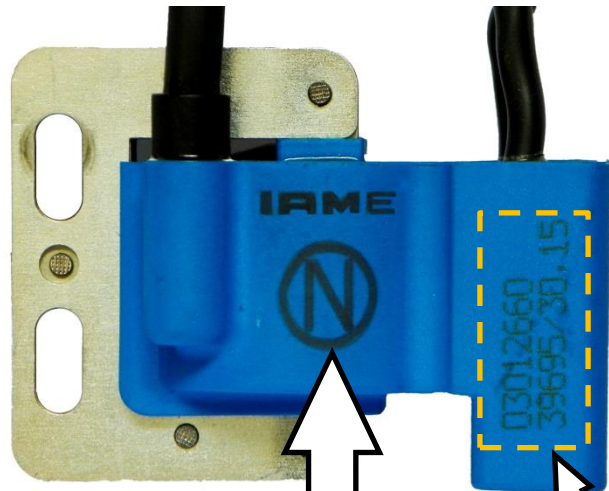

VARIABLE



**EXHAUST MUFFLER VIEW AND DIMENSIONS**  
**VUE ET DIMENSIONS DU SILENCIEUX D' ECHAPPEMENT**

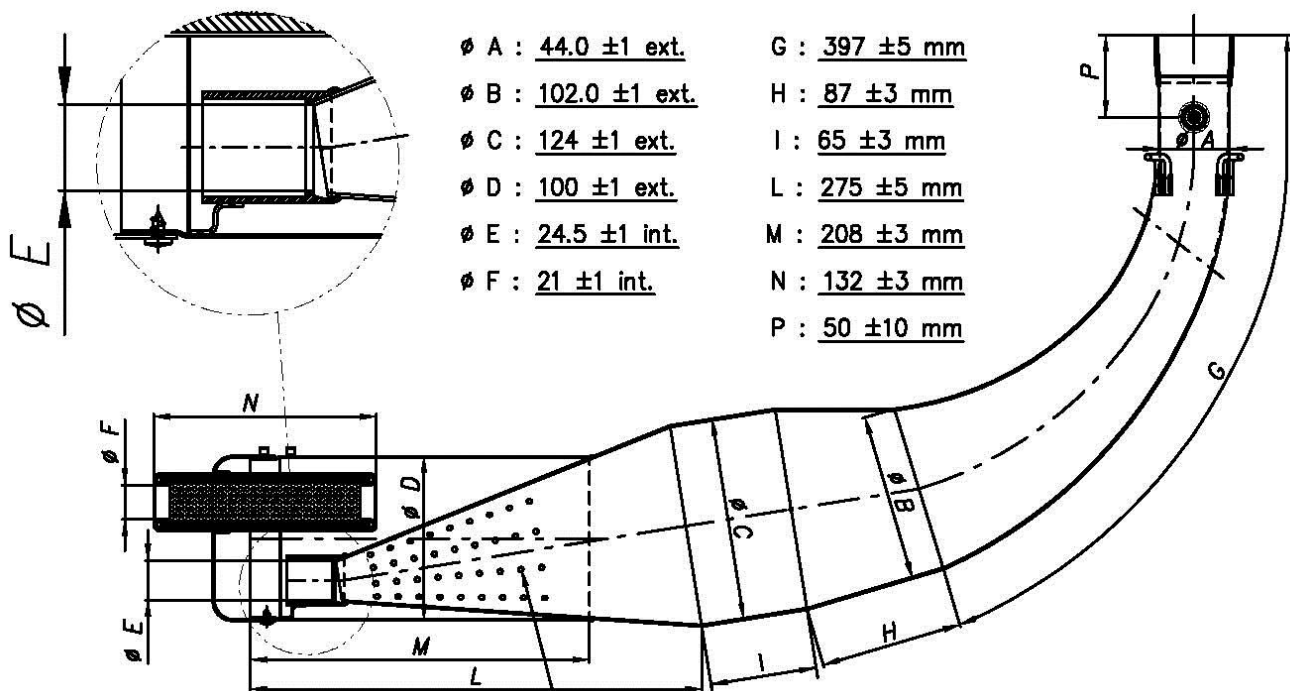

Min. weight 2.07 Kg  
 Poids min. 2.07 Kg

**N° 8 ROWS OF HOLES. THE ROWS ARE COMPOSED OF N°9 HOLES  $\phi 3$ , FOR A TOT OF 72 HOLES. THE HOLES HAVE A TOLLERANCE OF  $\pm 0.2$**   
**N° 8 RANGEES DE TROUS. LES RANGEES SE COMPOSENT DE N°9 TROUS  $\phi 3$ , POUR UN TOTAL DE 72 TROUS. LES TROUS ONT UNE TOLLERANCE DE  $\pm 0.2$**

**EXHAUST MANIFOLD AND SPACER VIEW AND DIMENSIONS**  
**VUE ET DIMENSIONS DU RACCORD D' ECHAPPEMENT ET ESPACEUR**

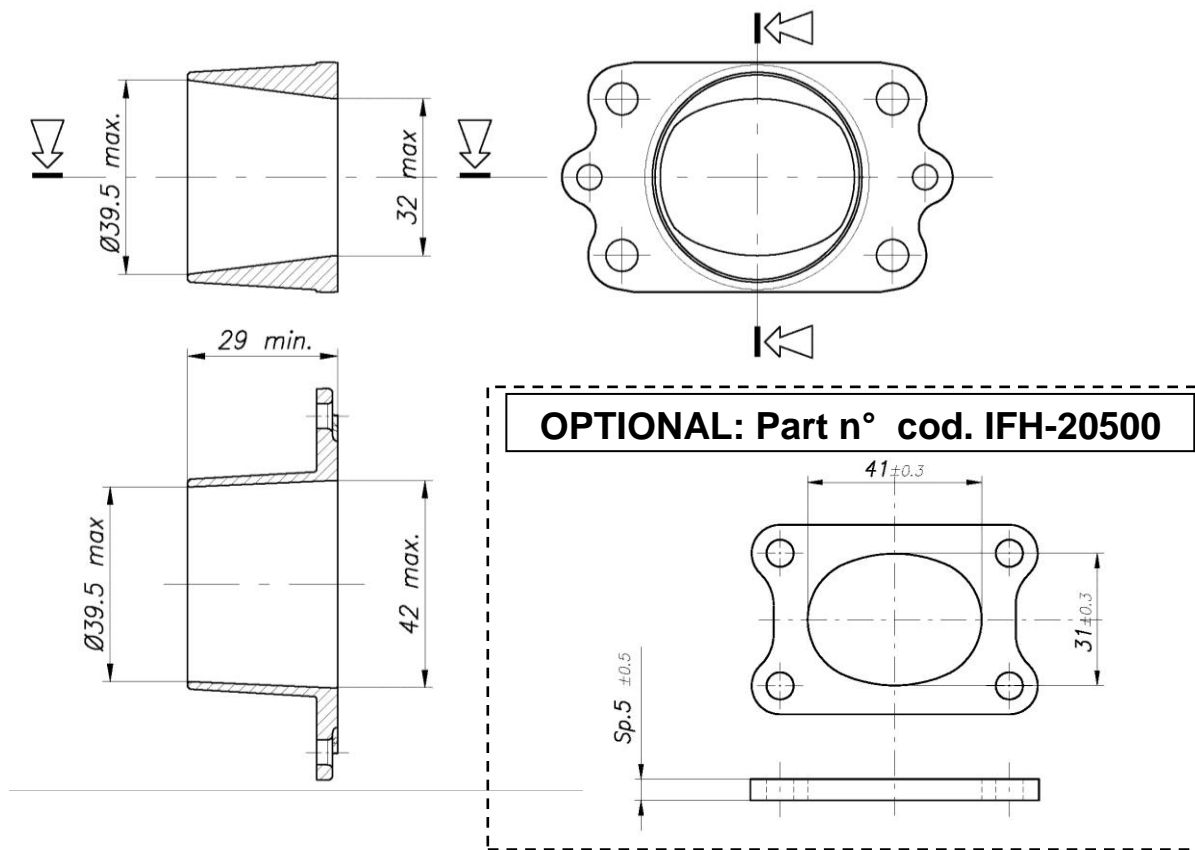

PISTON IDENTIFICATION MARKING  
 MARQUAGE D'IDENTIFICATION PISTON

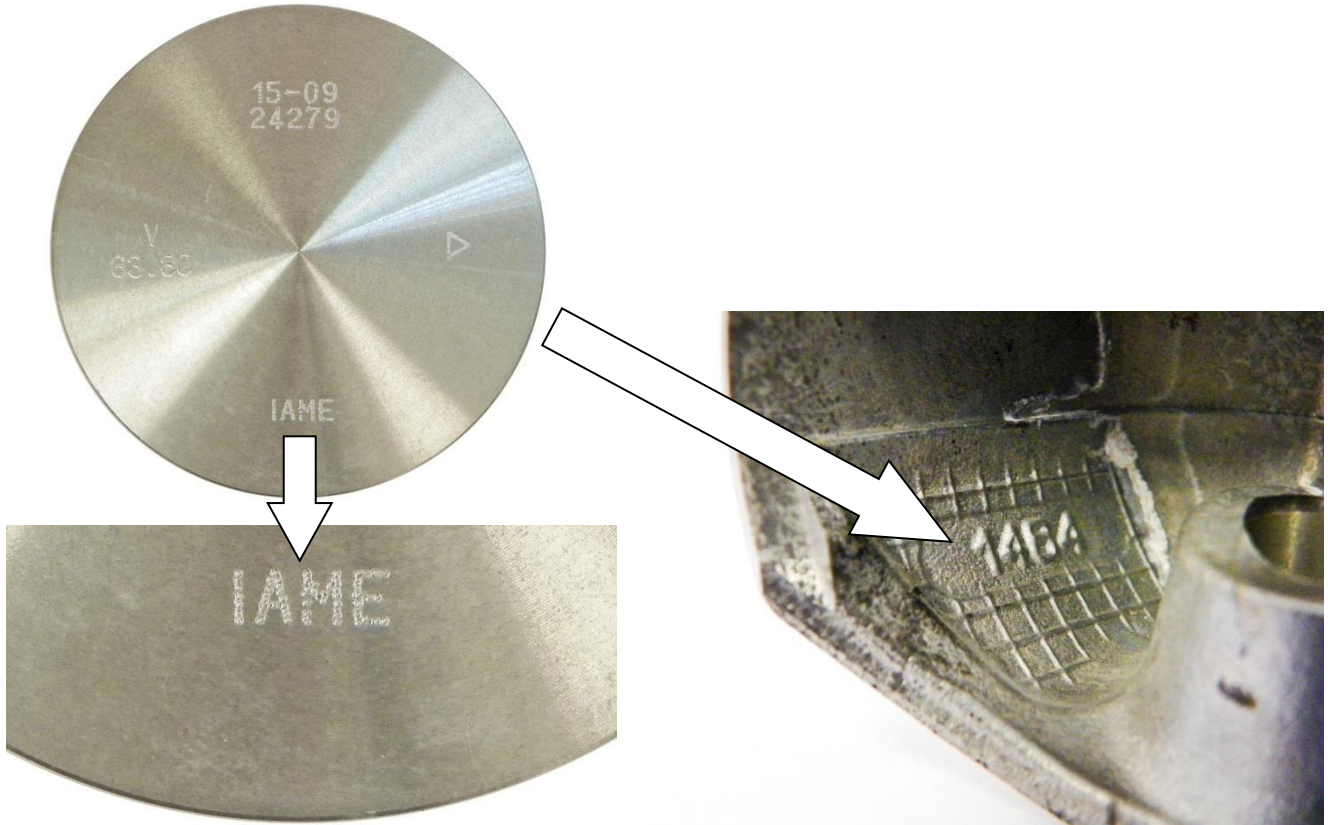
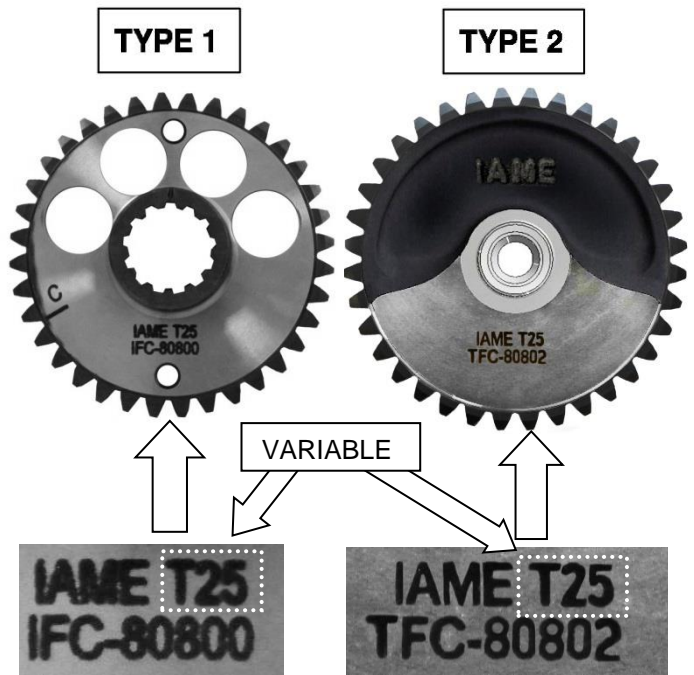

PHOTO IDENTIFICATION CONROD  
 MARQUAGE D'IDENTIFICATION BIELLE



IDENTIFICATION BALANCING SHAFT  
 MARKING  
 MARQUAGE D'IDENTIFICATION ARBRE  
 D'EQUILIBRAGE



CRANKSHAFT IDENTIFICATION MARKING  
 MARQUAGE D'IDENTIFICATION DU VILEBREQUIN

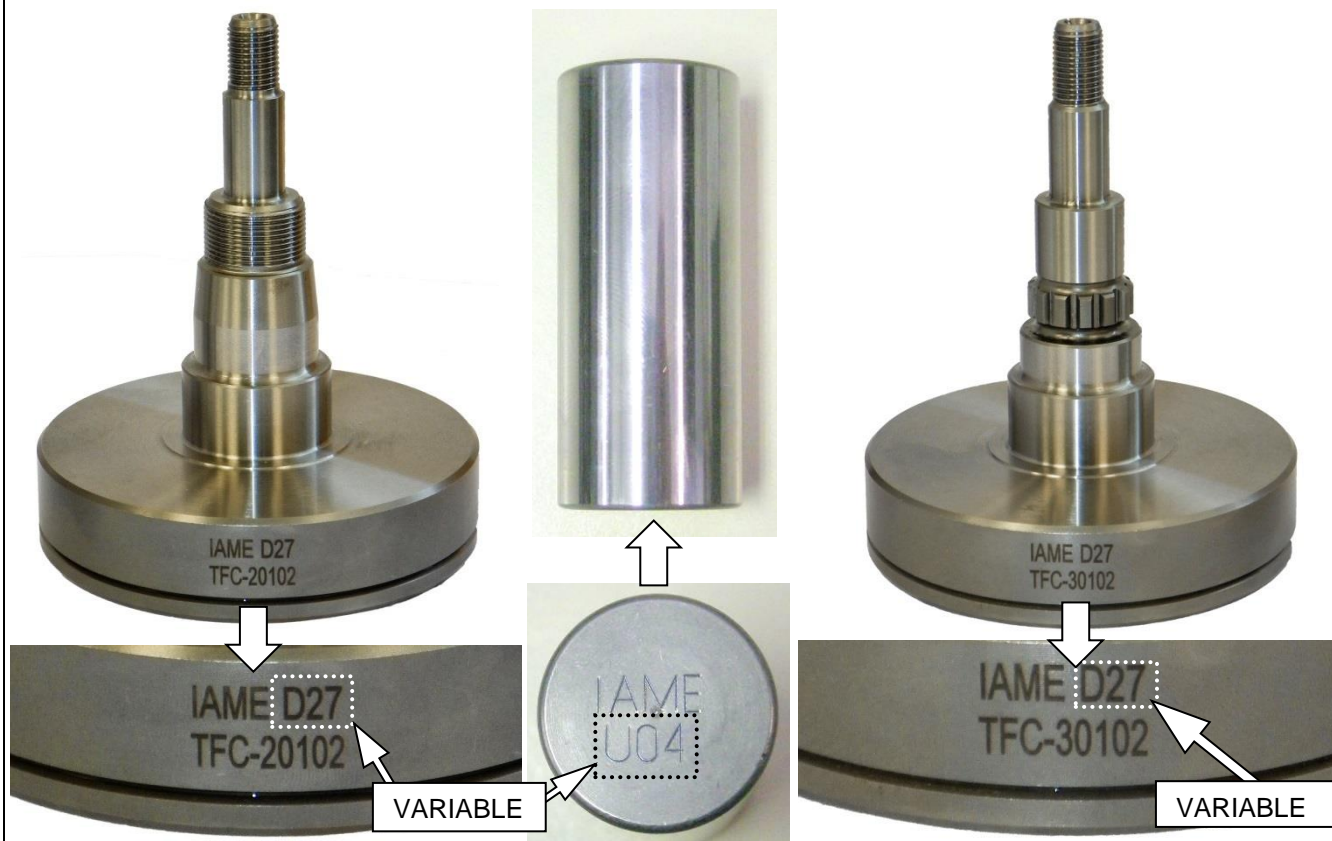

GEAR COMMAND BALANCING SHAFT  
 IDENTIFICATION MARKING  
 MARQUAGE D'IDENTIFICATION  
 ENGRENAGE ARBRE D'EQUILIBRAGE

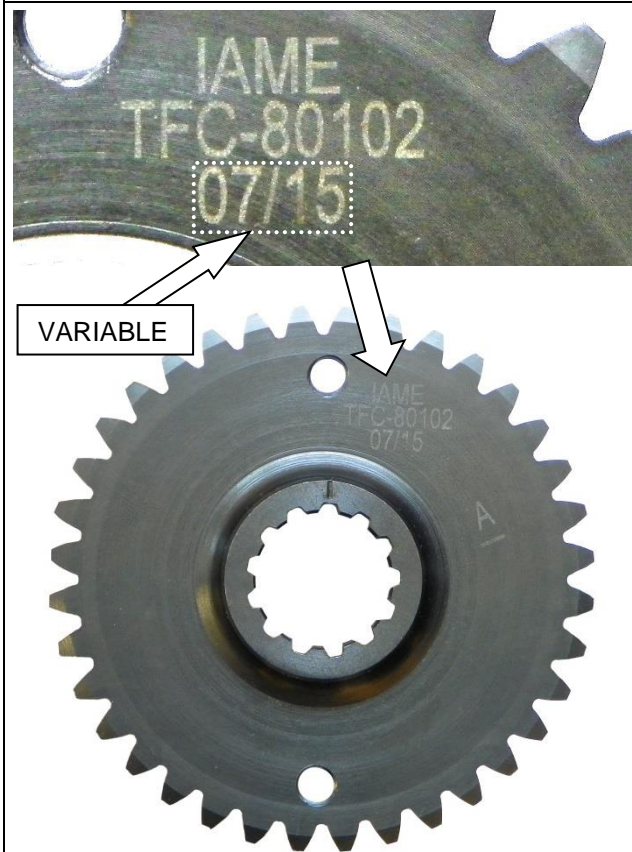

STARTER IDENTIFICATION MARKING  
 MARQUAGE D'IDENTIFICATION DU  
 MOTEUR DEMARREUR



CLUTCH HUB IDENTIFICATION MARKING  
 MARQUAGE D'IDENTIFICATION CORPS DE  
 EMBRAYAGE

SPROCKET IDENTIFICATION MARKING  
 MARQUAGE D'IDENTIFICATION DU PIGNON

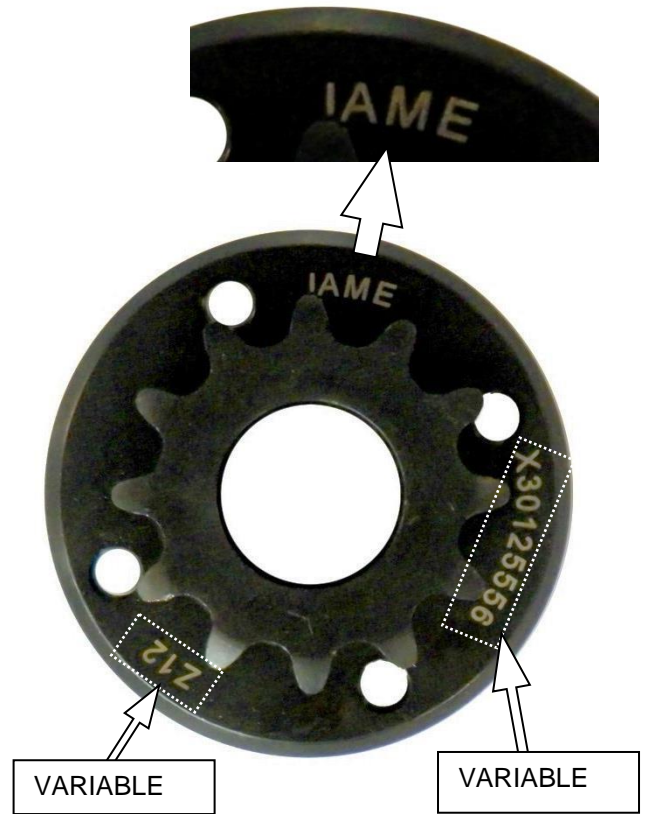
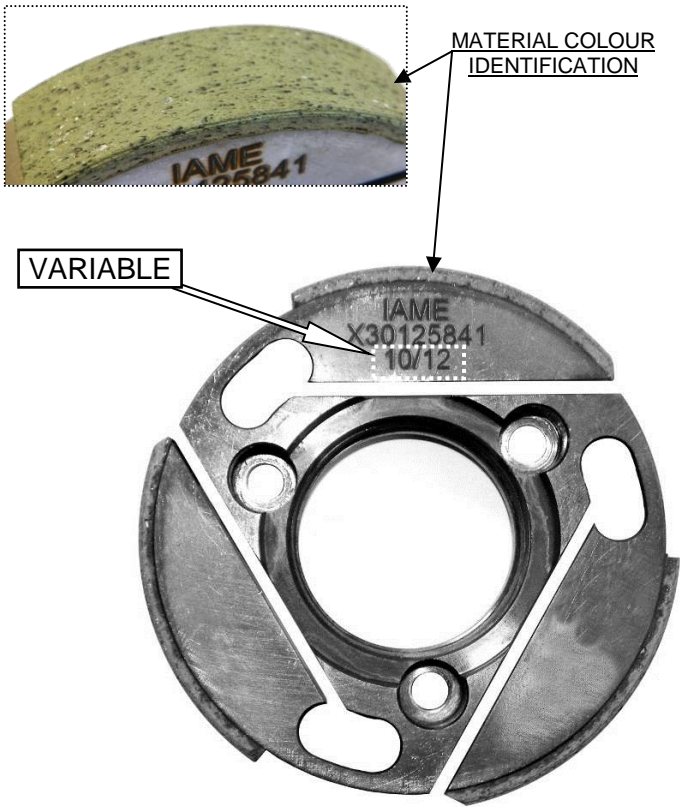

STARTER RING IDENTIFICATION MARKING  
 MARQUAGE D'IDENTIFICATION DE LA  
 COURONNE DE DEMARRAGE

CLUTCH DRUM IDENTIFICATION MARKING  
 MARQUAGE D'IDENTIFICATION DE LA  
 CALOTTE

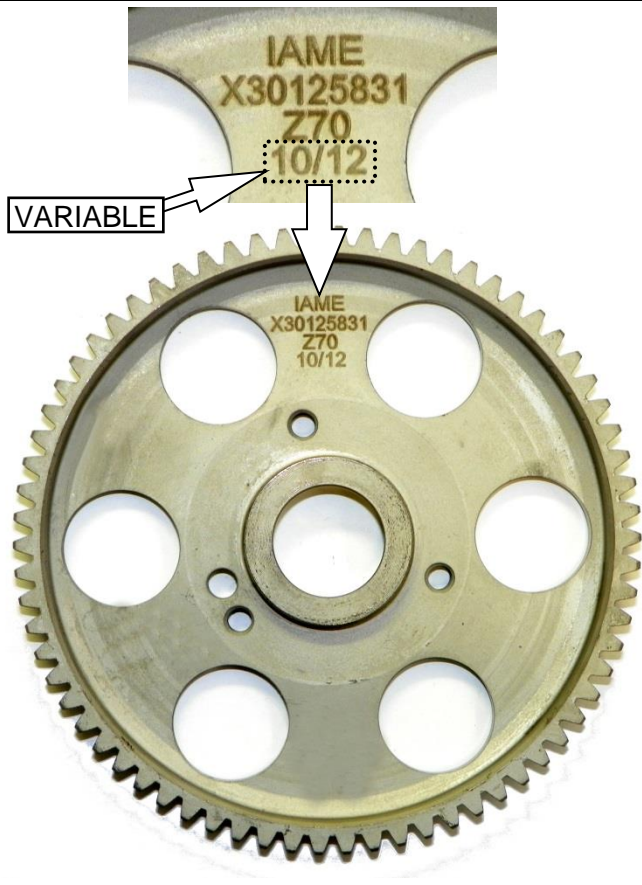

REED GROUP & PETALS IDENTIFICATION PHOTO  
PHOTO D'IDENTIFICATION DE LA PYRAMIDE DE CLAPETS & CLAPETS

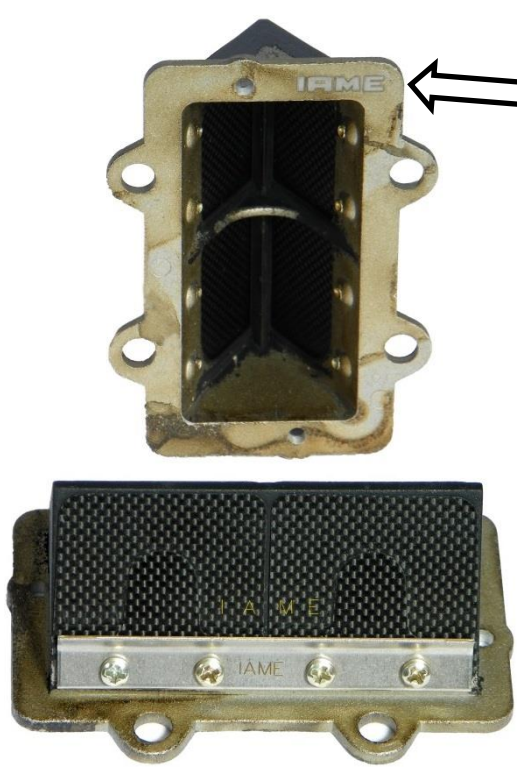

MATERIAL: CARBON FIBER



EXHAUST SILENCER IDENTIFICATION  
MARKING  
MARQUAGE D'IDENTIFICATION  
ECHAPPEMENT

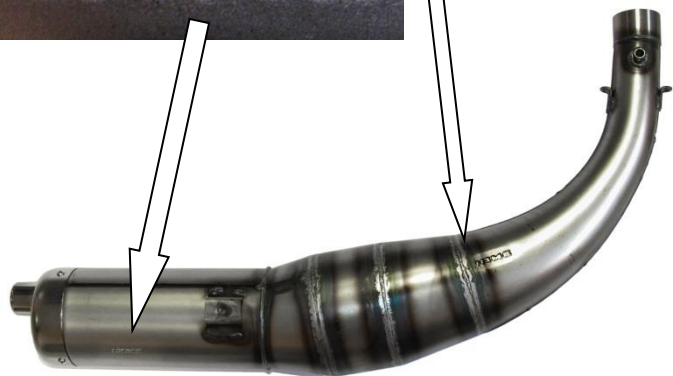

BENDIX COVER IDENTIFICATION MARKING  
MARQUAGE D'IDENTIFICATION DU COUVERCLE  
DU CONTRE-ARBRE DE DEMARRAGE

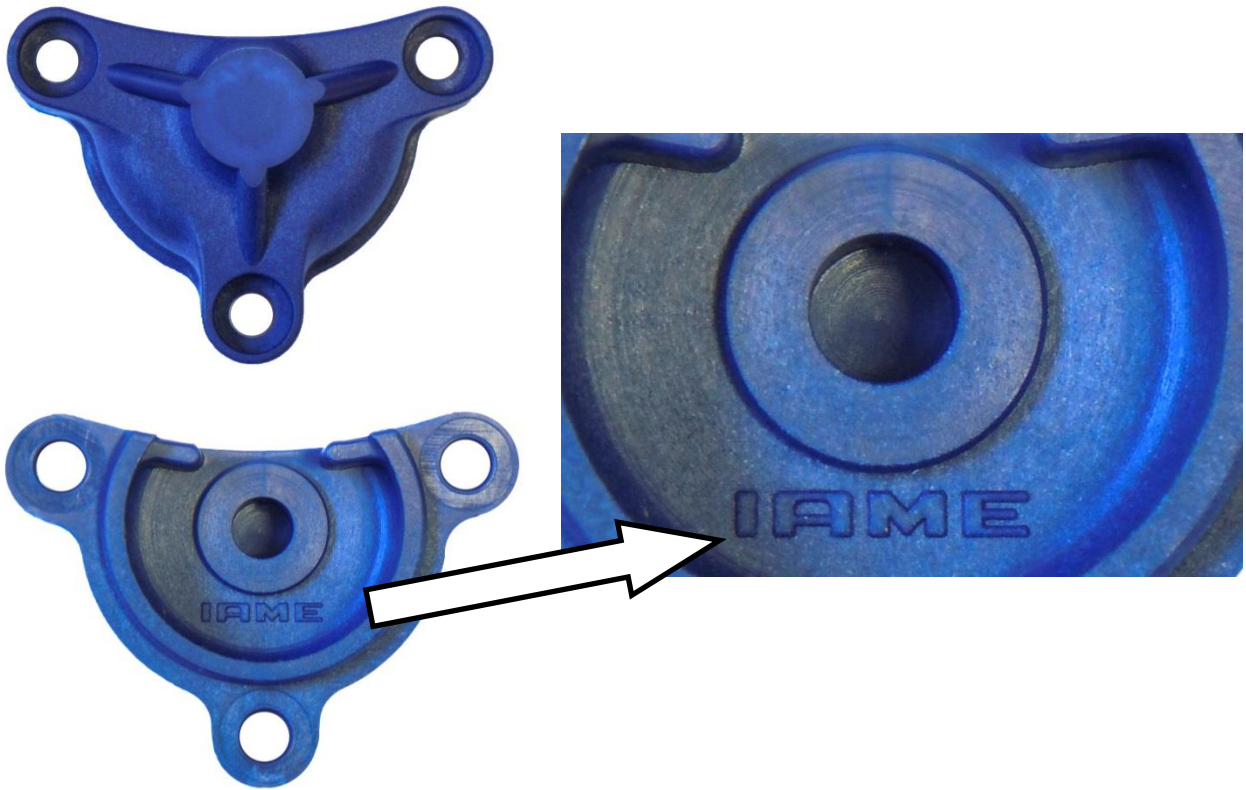

EXHAUST MANIFOLD IDENTIFICATION  
MARKING  
MARQUAGE DU RACCORD  
D'ECHAPPEMENT



CLUTCH COVER IDENTIFICATION  
MARKING  
MARQUAGE DU COUVERCLE  
D'EMBRAYAGE

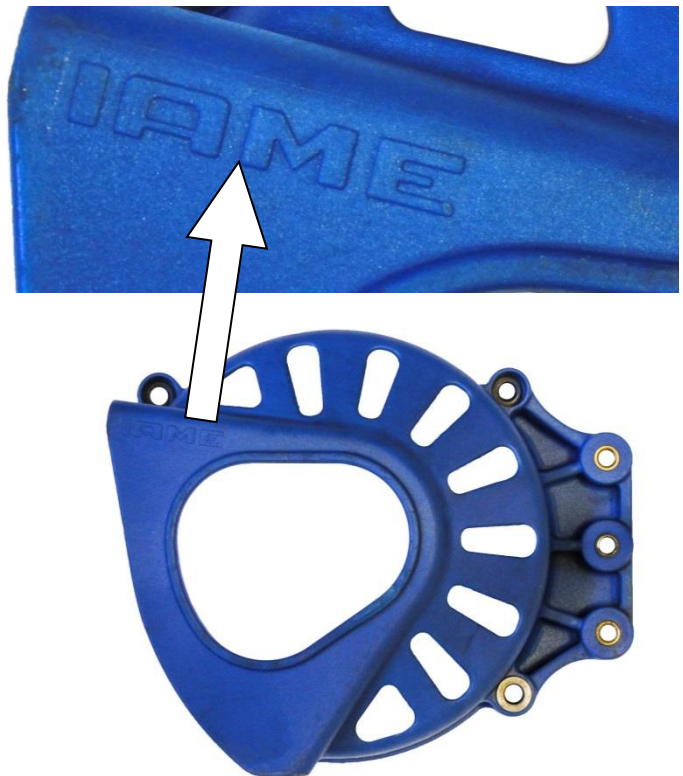



STICKER APPLICATION AREA - *ESPACE POUR L'APPLICATION DE ADHÉSIFS*

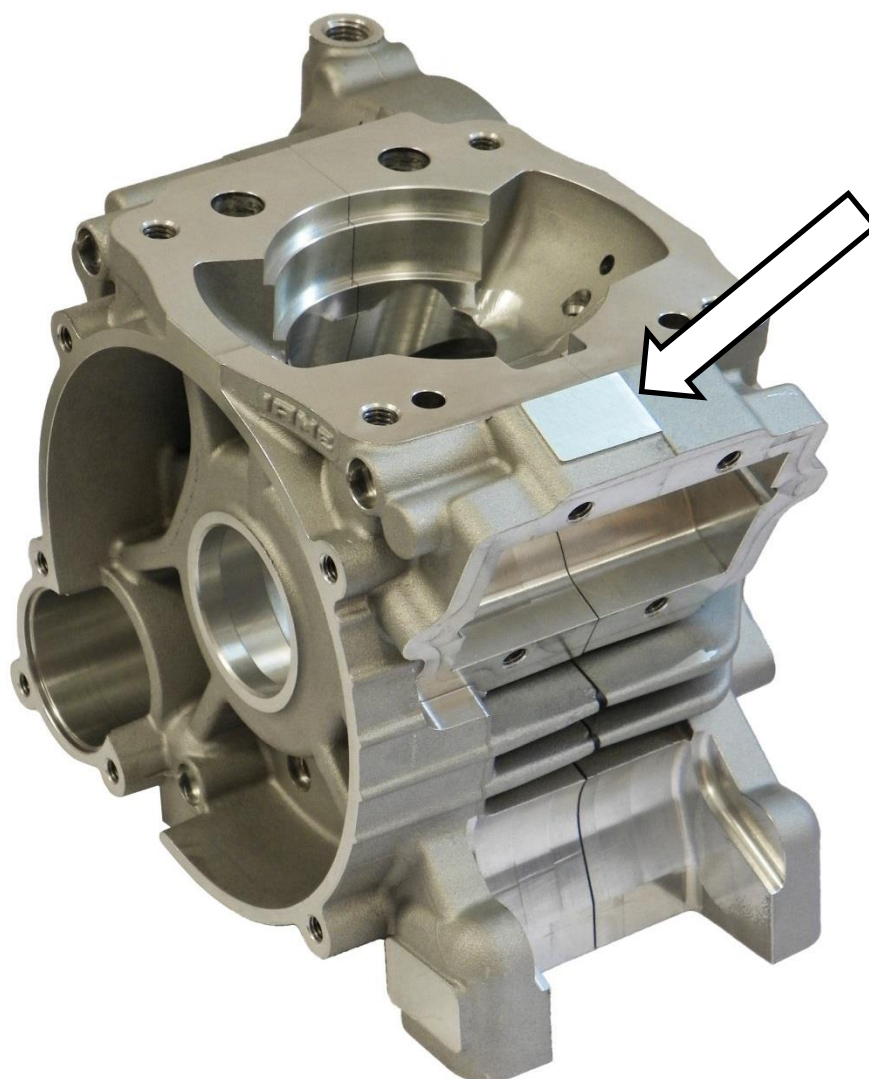
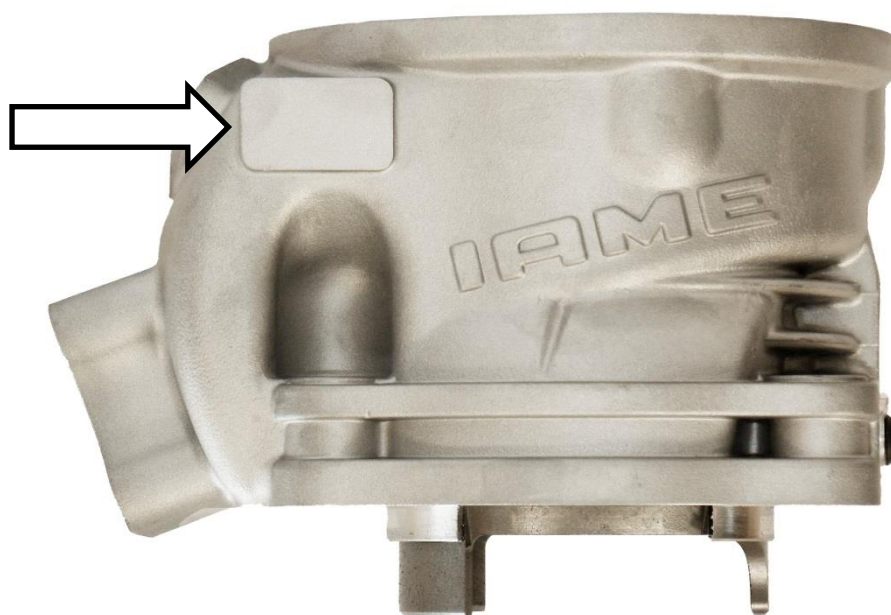

CYLINDER IDENTIFICATION MARKING  
MARQUAGE D'IDENTIFICATION DU CYLINDRE

